



ORDERING GUIDE

TRUCK NON-STEER LIFT AXLE

If additional options are required and do not appear on this guide, please note when ordering. This sheet contains basic information.

TO: _____ FROM: _____

COMPANY NAME: _____

DATE: _____ PHONE: _____ FAX: _____

E-MAIL: _____

1 SUSPENSION TYPE AND CAPACITY SELECTION			
12K	<input type="checkbox"/> AL1200DB* – Drawbar with trailer style round tube axle.		
13.5K	<input type="checkbox"/> AL1300 – Kit only or with trailer style round tube axle.		
	<input type="checkbox"/> AL1395 – Susp. with fabricated axle. FF spindle only		
16K	<input type="checkbox"/> AL1600DB* – Drawbar with trailer style round tube axle.		
19K	<input type="checkbox"/> AL1900 – Kit only or with trailer style round tube axle.		
	<input type="checkbox"/> AL1900DB* – Drawbar with trailer style round tube axle.		
25K	<input type="checkbox"/> AL2200 – Kit only or with trailer style round tube axle.		
	Rail Type:	<input type="checkbox"/> SR	<input type="checkbox"/> SSR** (4.25" shorter fore/aft)
			<input type="checkbox"/> Roll Off (Cannot use 9" drop axle)
	Alignment Style:	<input type="checkbox"/> Weld Collar	<input type="checkbox"/> Eccentric Collar

* Tag position only

2 VEHICLE INFORMATION (all information required)			
Lift Axle Position	<input type="checkbox"/> Pusher (Ahead of Drive Axles)	<input type="checkbox"/> Tag (Behind Drive Axles)	
Vehicle's Primary Suspension Type	<input type="checkbox"/> Air Ride	<input type="checkbox"/> Rubber Block	<input type="checkbox"/> Mech. Spring
	<input type="checkbox"/> Walking Beam		
Vehicle Frame Width (outside to outside)	<input type="checkbox"/> 33.5" <input type="checkbox"/> 34" <input type="checkbox"/> 34.5" <input type="checkbox"/> 35"	Other (please specify _____)	
Dimension from Bottom of Frame Rail to Ground (at lift axle location)	Unloaded _____ Loaded _____		
Dimension from Bottom of Frame Rail to Bottom of Driveshaft (at lift axle location)	_____		
Lift Axle Tire Size	_____		

3 LIFT AXLE OPTIONS			
--Ride Height-- Must be configured and meet specific model acceptable ranges based on the vehicle "loaded" frame height. All clearances above and below lift axle tires, and at the driveline must be confirmed by installer. (See Figure 1)	Available ride heights/ranges vary with each specific model and availability will be confirmed during ordering process. Values shown below represent nominal target heights.		
	<input type="checkbox"/> 7"	<input type="checkbox"/> 8"	<input type="checkbox"/> 9"
	<input type="checkbox"/> 10"	<input type="checkbox"/> 11"	<input type="checkbox"/> 12"
	<input type="checkbox"/> 13"	<input type="checkbox"/> 14"	<input type="checkbox"/> 15"
	<input type="checkbox"/> 16"	<input type="checkbox"/> 17"	<input type="checkbox"/> 18"
	<input type="checkbox"/> 19"	<input type="checkbox"/> 20"	<input type="checkbox"/> 21"

Rail	<input type="checkbox"/> Blank, no holes	<input type="checkbox"/> With Mounting Holes - Specific hole pattern must be furnished		
Vertical Shock Kit	<input type="checkbox"/> Yes		<input type="checkbox"/> No	
Brakes	<input type="checkbox"/> Less brakes			
	<input type="checkbox"/> 12 1/4" X 7 1/2"			
	<input type="checkbox"/> 15 X 4 (FF spindle only)			
	<input type="checkbox"/> 16.5 X 7 (25K only)			
Brake Chambers	<input type="checkbox"/> N/A	<input type="checkbox"/> Type 20	<input type="checkbox"/> Type 24	<input type="checkbox"/> Type 30
	<input type="checkbox"/> Type 2424		<input type="checkbox"/> Type 2430	<input type="checkbox"/> Type 3030
Dust Shields	<input type="checkbox"/> Yes		<input type="checkbox"/> No	

4 AXLE BEAM OPTIONS			
Axle Beam	<input type="checkbox"/> Less Axle	<input type="checkbox"/> With Axle (select from options below. Options shown may not apply to all suspension models)	
Spindle Type			
<input type="checkbox"/> FF Spindle		<input type="checkbox"/> N Spindle	<input type="checkbox"/> P Spindle
Axle Type			
Straight	<input type="checkbox"/> 92" Hub Face (FF Spindle Only) 13,200 Lbs. Beam Rating		
	<input type="checkbox"/> 98" Hub Face (FF Spindle Only) 13,200 Lbs. Beam Rating		
	<input type="checkbox"/> 71 1/2" Axle Track, 5/8" Wall 22,500 Lbs. Beam Rating @ 34" Arm Centers		
	<input type="checkbox"/> 71 1/2" Axle Track, 3/4" Wall 25,000 Lbs. Beam Rating @ 34" Arm Centers		
	<input type="checkbox"/> 77 1/2" Axle Track, 5/8" Wall 19,290 Lbs. Beam Rating @ 34" Arm Centers		
	<input type="checkbox"/> 77 1/2" Axle Track, 3/4" Wall 21,440 Lbs. Beam Rating @ 34" Arm Centers		
6" Bent Tube	<input type="checkbox"/> 92" Hub Face (FF Spindle Only) 13,200 Lbs. Beam Rating		
	<input type="checkbox"/> 98" Hub Face (FF Spindle Only) 13,200 Lbs. Beam Rating		
	<input type="checkbox"/> 71 1/2" Axle Track, 5/8" Wall 20,100 Lbs. Beam Rating @ 34" Arm Centers		
	<input type="checkbox"/> 71 1/2" Axle Track, 3/4" Wall 22,500 Lbs. Beam Rating @ 34" Arm Centers		
9" Bent Tube (AL2200 Only)	<input type="checkbox"/> 77 1/2" Axle Track, 3/4" Wall 19,200 Lbs. Beam Rating @ 34" Arm Centers		
	<input type="checkbox"/> 71 1/2" Axle Track, 5/8" Wall 18,500 Lbs. Beam Rating @ 34" Arm Centers		

Contact Watson & Chalin at **972.547.6020** for additional information



Watson & Chalin
725 E. University Drive, McKinney, Texas 75069
972.547.6020 • 800.445.0736 • Fax 972.542.0097

www.watsonsuspensions.com



W&C176 05-2017

Watson & Chalin is a brand of Hendrickson

Information contained in this literature was accurate at the time of publication. Product changes may have been made after the copyright date that are not reflected. © Watson & Chalin Mfg. Inc. All Rights Reserved Printed in United States of America

5 WHEEL-END OPTIONS			
Hub	<input type="checkbox"/> Less Wheel-ends	<input type="checkbox"/> Standard hub	<input type="checkbox"/> Preset Plus
Hub Style	<input type="checkbox"/> Hub Pilot (Standard)		<input type="checkbox"/> Stud Pilot
Hub Options	<input type="checkbox"/> Cast		<input type="checkbox"/> Aluminum
ABS Tone Ring	<input type="checkbox"/> Less Tone Ring	<input type="checkbox"/> Tone Ring Installed	
Drum Options	<input type="checkbox"/> Cast		<input type="checkbox"/> Cast for 19.5 wheels (13.5K with 15 X 4 brakes only)
	<input type="checkbox"/> Castlite	<input type="checkbox"/> Less Drums	
Wheel-end Fasteners	<input type="checkbox"/> Wheel-end fasteners included		<input type="checkbox"/> Less wheel-end fasteners
Wheel-end Lube	<input type="checkbox"/> No Lube	<input type="checkbox"/> Std. Oil	<input type="checkbox"/> Synthetic Oil
ABS Sensor	<input type="checkbox"/> Less ABS Sensor Cables		<input type="checkbox"/> ABS Sensor Cables Installed

Figure 1 - Ride Height Illustration

- A** Ground to Bottom of Vehicle Frame (loaded) _____
- B** Static Loaded Tire Radius - _____
- C** Ride Height = _____

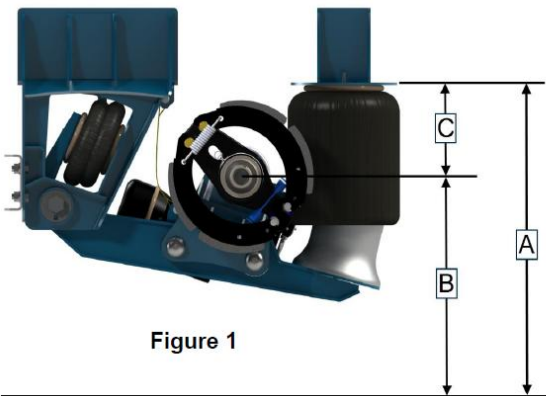

Figure 1

6 PLUMBING OPTIONS (not available for all models)		
Plumbing	<input type="checkbox"/> Less Plumbing	<input type="checkbox"/> Pre-plumbing Included (select from options below)
Plumbing Kit Variations (select one main and one control option)		
Main Kit	Control Option	
<input type="checkbox"/> PPAK55 Air kit for use with multi-port spool-type control valve	<input type="checkbox"/> Less Controls	
	<input type="checkbox"/> Regulator/gauge combo w/bracket (no push/pull valve)	
	<input type="checkbox"/> Control panel with manual push/pull valve, regulator, gauge	
<input type="checkbox"/> PPAK250 Air kit utilizing high-flow elec. Lift Axle Control Module. 12V relay included.	<input type="checkbox"/> Control panel with 12v push/pull valve, regulator, gauge, 12v relay	
	<input type="checkbox"/> Control panel with regulator and gauge only (no control valve)	
	<input type="checkbox"/> No control panel, elec. 12v valve, regulator, gauge, 12v relay	
	<input type="checkbox"/> Less Controls	
<input type="checkbox"/> PPAK124 Air kit utilizing proportioning ratio valve in place of manual regulator. 25K units only.	<input type="checkbox"/> Regulator/gauge combo w/bracket (no push/pull valve)	
	<input type="checkbox"/> Control panel with regulator and gauge (no push/pull valve)	
	<input type="checkbox"/> Control panel with regulator and gauge in weather box (no push/pull valve)	
	<input type="checkbox"/> Control panel with regulator, gauge and push/pull valve in weather box	
<input type="checkbox"/> PPAK124 Air kit utilizing proportioning ratio valve in place of manual regulator. 25K units only.	<input type="checkbox"/> Less Controls	
	<input type="checkbox"/> Control panel with regulator and gauge (no push/pull valve)	

NOTES OR ADDITIONAL OPTIONS NOT LISTED

Contact Watson & Chalin at **972.547.6020** for additional information



Watson & Chalin
725 E. University Drive, McKinney, Texas 75069
972.547.6020 • 800.445.0736 • Fax 972.542.0097

www.watsonsuspensions.com

