

# SINGLE POINT 44K

SINGLE POINT SPRING SUSPENSION

# SP SERIES

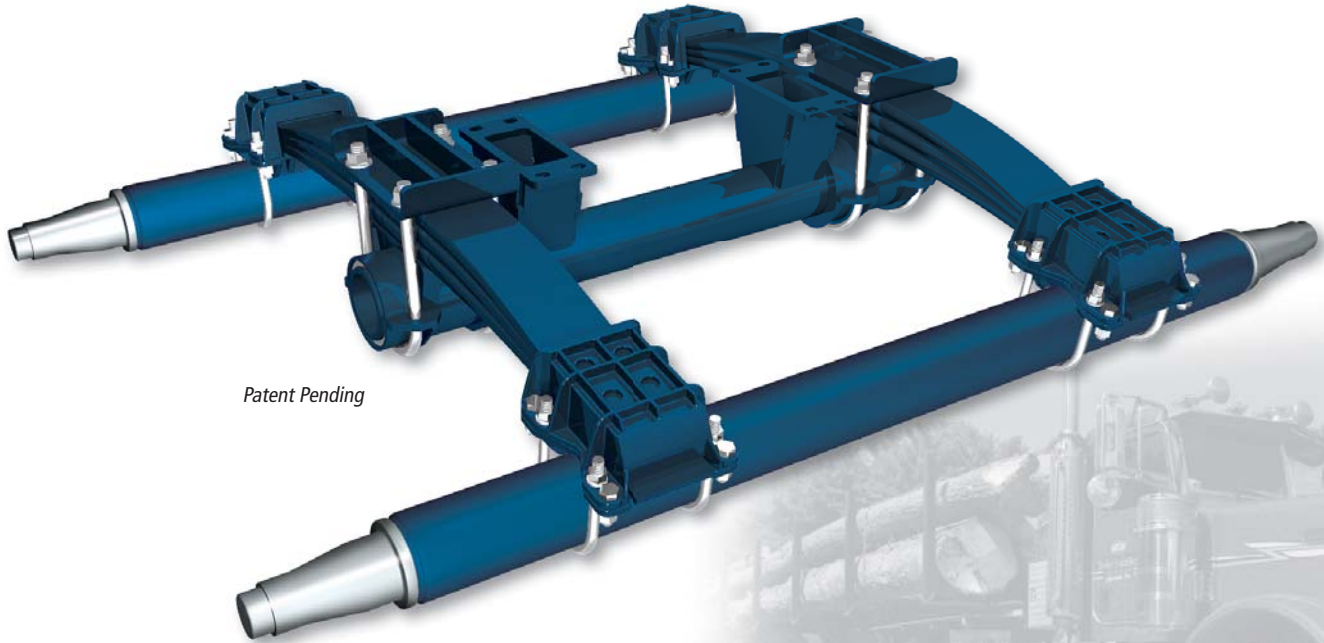

## SINGLE POINT 44K

The new patent pending **Single Point 44K** suspension is designed for applications such as end-dump and logging trailers. Our new 5-inch trunnion tube provides improved stiffness with the advantage of saving weight. The new 3-leaf parabolic design improves durability for the road ahead. Another benefit across all applications is the new lighter weight axle seat which are easier to align. Common axle beams are 37- and 38-inch spring centers for 71.5-inch track axles and 43- to 44-inch spring centers common for 77.5-inch track axles.

- Capacity: 44,000 pounds
- New lighter adjustable axle seats
- Long-life trunnion bushings
- Accommodates any standard axle tracks
- Compatible with drum or disc brakes
- 5-year limited warranty\*

\* Contact your local W&C representative for complete warranty terms, conditions and limitations.

**For more information, call 800.445.0736**



Watson & Chalin is a brand of Hendrickson

## Heavy Vocational Single Point Suspension

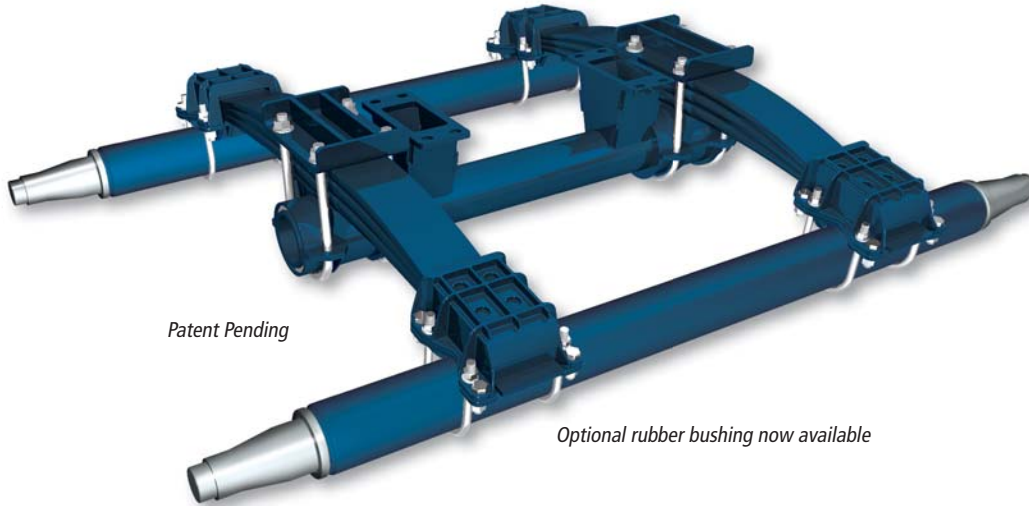

Patent Pending

Optional rubber bushing now available

- Designed for on- and off-road
- New 5-inch trunnion tube
- New 3-leaf parabolic design
- Lighter weight
- Variable ride heights coming soon

### Applications



- Dump
- Refuse / Waste



- Severe-duty
- Oil Industry



- Pole
- Logging

Contact Watson & Chalin at **972.547.6020** for additional information.



**Watson & Chalin**  
725 E. University Drive, McKinney, Texas 75069  
972.547.6020 • 800.445.0736 • Fax 972.542.0097  
[www.watsonsuspensions.com](http://www.watsonsuspensions.com)

